

---

## MAIN CHARACTERISTICS

Frequency range	: 144 - 164 MHz
Input impedance	: 50 ohm
V.S.W.R.	: < 1.4:1
Maximum rated RF power	: 100 watt
Tx-Rx insertion loss	: < 1.2 dB
Tx-Rx isolation	: > 80 dB
Frequency stability	: 4.5 ppm/C°
Type of connection	: BNC female (Tx-RX) : N female (antenna)
Cavity material	: Aluminium alloy DIN 3.2306
Treatment	: Chemical conversion coating : MIL-C-5541 with grey varnish RAL 7001
Elements material	: Brass passivated
Working temperature	: From -35° to +80°
Dimensions	: 33 x 157 x 212 mm
Net weight	: abt. 1100 g

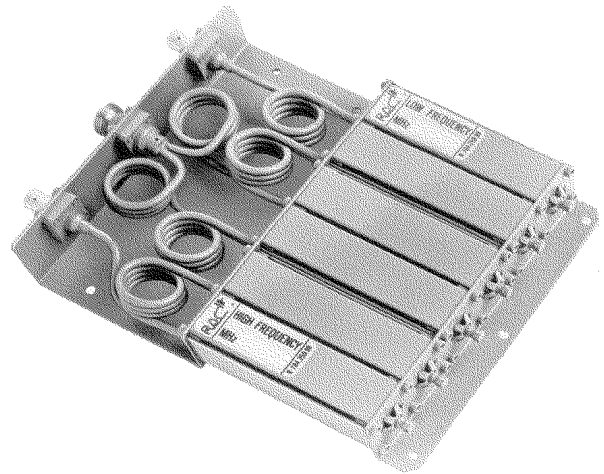

---

## MAIN CHARACTERISTICS

Frequency range	: 154 - 174 MHz
Input impedance	: 50 ohm
V.S.W.R.	: < 1.4:1
Maximum rated RF power	: 100 watt
Tx-Rx insertion loss	: < 1.2 dB
Tx-Rx isolation	: > 80 dB
Frequency stability	: 4.5 ppm/C°
Type of connection	: BNC female (Tx-RX) : N female (antenna)
Cavity material	: Aluminium alloy DIN 3.2306
Treatment	: Chemical conversion coating : MIL-C-5541 with grey varnish RAL 7001
Elements material	: Brass passivated
Working temperature	: From -35° to +80°
Dimensions	: 33 x 157 x 212 mm
Net weight	: abt. 1100 g

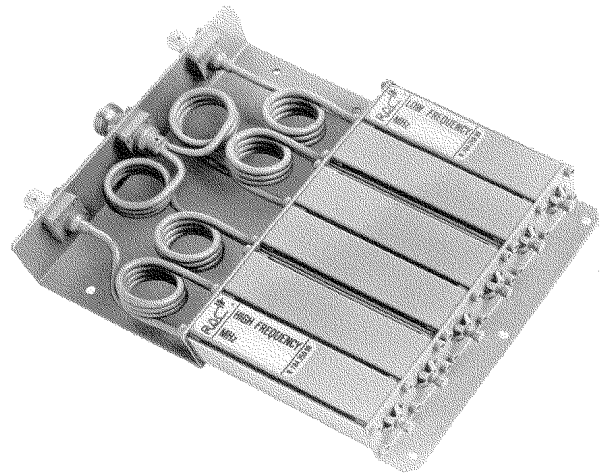

---

## MAIN CHARACTERISTICS

Frequency range	: 380 - 430 MHz
Input impedance	: 50 ohm
V.S.W.R.	: < 1.4:1
Maximum rated RF power	: 100 watt
Tx-Rx insertion loss	: < 1.2 dB
Tx-Rx isolation	: > 85 dB
Frequency stability	: 4.5 ppm/C°
Type of connection	: BNC female (Tx-RX) : N feamale (antenna)
Cavity material	: Aluminium alloy DIN 3.2306
Treatment	: Chemical conversion coating : MIL-C-5541 with grey varnish RAL 7001
Elements material	: Brass passivated
Working temperature	: From -35° to +80°
Dimensions	: 33 x 157 x 247 mm
Net weight	: abt. 1350 g

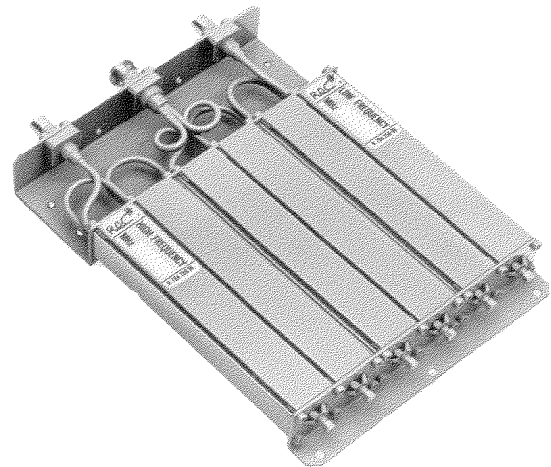

---

## MAIN CHARACTERISTICS

Frequency range	: 420 - 470 MHz
Input impedance	: 50 ohm
V.S.W.R.	: < 1.4:1
Maximum rated RF power	: 100 watt
Tx-Rx insertion loss	: < 1.2 dB
Tx-Rx isolation	: > 85 dB
Frequency stability	: 4.5 ppm/C°
Type of connection	: BNC female (Tx-RX) : N feamale (antenna)
Cavity material	: Aluminium alloy DIN 3.2306
Treatment	: Chemical conversion coating : MIL-C-5541 with grey varnish RAL 7001
Elements material	: Brass passivated
Working temperature	: From -35° to +80°
Dimensions	: 33 x 157 x 230 mm
Net weight	: abt. 1350 g

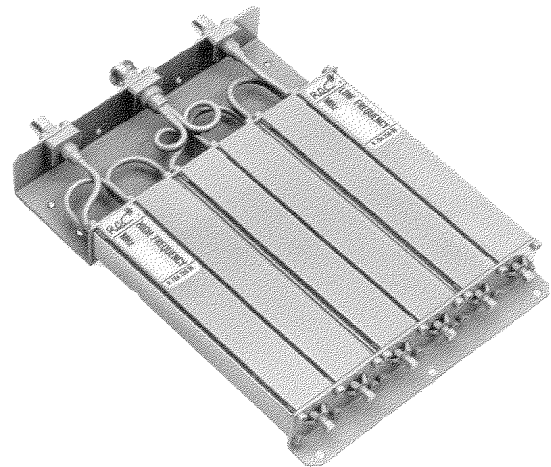

Two way coupler find its application in arrays of  
in arrays of Yagi antenna.  
High performance, professional equipment.

**MAIN CHARACTERISTICS**

Frequency range	: 68 - 88 MHz
Input impedance	: 50 ohm
V.S.W.R.	: < 1.2:1
V.S.W.R. (1 gate open)	: < 2:1
Maximum rated RF power	: 1000 watt
Insertion loss	: 0.1 dB
Type of connection	: N female
Hermetic seal	: Pass helium leak test of 1x10 <sup>-10</sup> cc/sec
Inner conductor	: Brass silver plated
Housing material	: Aluminium alloy DIN 3.3206
Net weight	: 620 g
Dimensions	: 25 x 50 x 430 mm
Working temperature	: From -35° to +80°

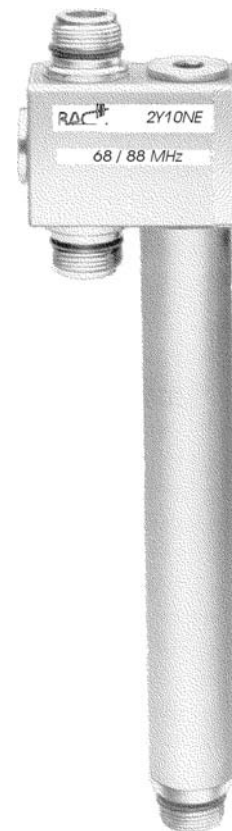

**VSWR CURVE**

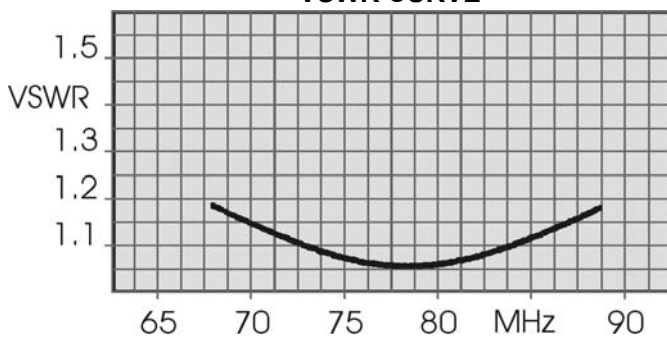

Two way coupler find its application in arrays of  
in arrays of Yagi antenna.  
High performance, professional equipment.

## MAIN CHARACTERISTICS

Frequency range	: 135 - 180 MHz
Input impedance	: 50 ohm
V.S.W.R.	: < 1.2:1
V.S.W.R. (1 gate open)	: < 2:1
Maximum rated RF power	: 1000 watt
Insertion loss	: 0.1 dB
Type of connection	: N female
Hermetic seal	: Pass helium leak test of 1x10 <sup>-10</sup> cc/sec
Inner conductor	: Brass silver plated
Housing material	: Aluminium alloy DIN 3.3206
Net weight	: 310 g
Dimensions	: 25 x 50 x 245 mm
Working temperature	: From -35° to +80°

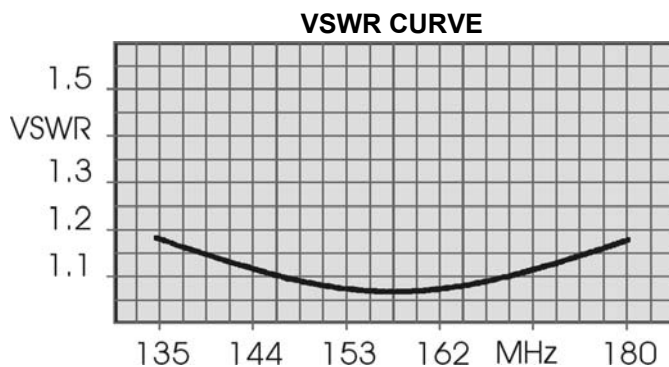

Four way coupler find its application in arrays of  
in arrays of Yagi antenna.  
High performance, professional equipment.

**MAIN CHARACTERISTICS**

Frequency range	: 152 - 174 MHz
Input impedance	: 50 ohm
V.S.W.R.	: < 1.2:1
V.S.W.R. (1 gate open)	: < 2:1
Maximum rated RF power	: 1000 watt
Insertion loss	: 0.1 dB
Type of connection	: N female
Hermetic seal	: Pass helium leak test of 1x10 <sup>-10</sup> cc/sec
Inner conductor	: Brass silver plated
Housing material	: Aluminium alloy DIN 3.3206
Net weight	: 400 g
Dimensions	: 25 x 72 x 210 mm
Working temperature	: From -35° to +80°

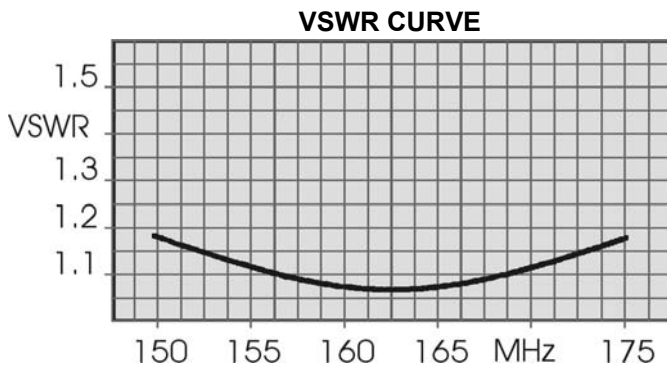
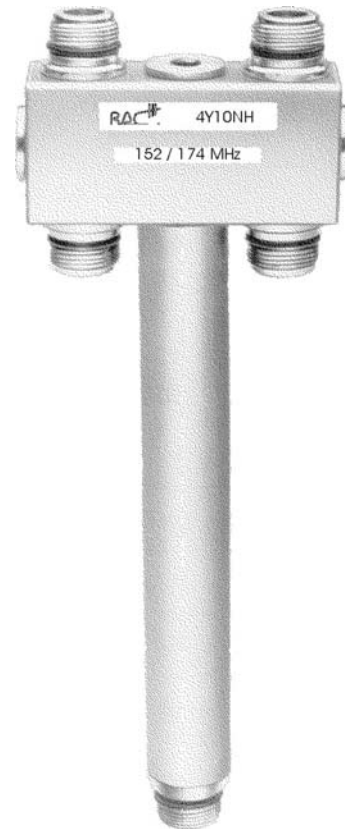

Two way coupler find its application in arrays of  
in arrays of Yagi antenna.  
High performance, professional equipment.

**MAIN CHARACTERISTICS**

Frequency range	: 400 - 520 MHz
Input impedance	: 50 ohm
V.S.W.R.	: < 1.2:1
V.S.W.R. (1 gate open)	: < 2:1
Maximum rated RF power	: 1000 watt
Insertion loss	: 0.1 dB
Type of connection	: N female
Hermetic seal	: Pass helium leak test of 1x10 <sup>-10</sup> cc/sec
Inner conductor	: Brass silver plated
Housing material	: Aluminium alloy DIN 3.3206
Net weight	: 230 g
Dimensions	: 25 x 50 x 135 mm
Working temperature	: From -35° to +80°

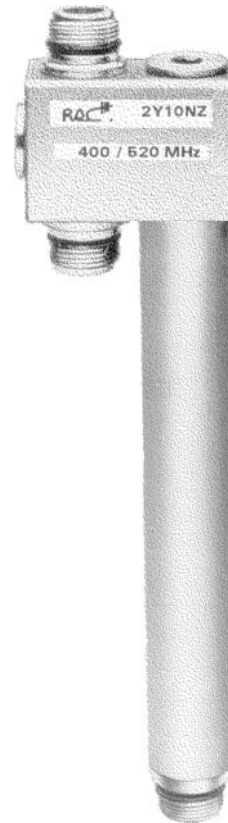

**VSWR CURVE**

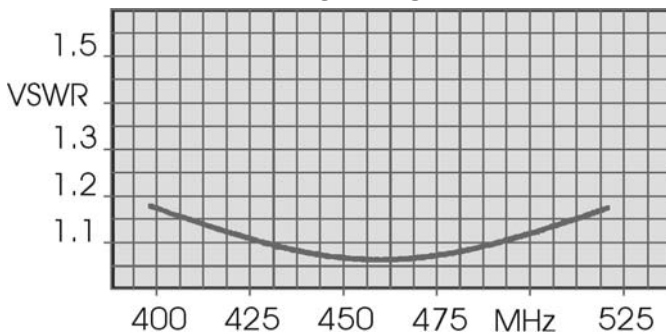



Four way coupler find its application in arrays of  
in arrays of Yagi antenna.  
High performance, professional equipment.

**MAIN CHARACTERISTICS**

Frequency range	: 415 - 470 MHz
Input impedance	: 50 ohm
V.S.W.R.	: < 1.2:1
V.S.W.R. (1 gate open)	: < 2:1
Maximum rated RF power	: 1000 watt
Insertion loss	: 0.1 dB
Type of connection	: N female
Hermetic seal	: Pass helium leak test of 1x10 <sup>-10</sup> cc/sec
Inner conductor	: Brass silver plated
Housing material	: Aluminium alloy DIN 3.3206
Net weight	: 300 g
Dimensions	: 25 x 72 x 125 mm
Working temperature	: From -35° to +80°

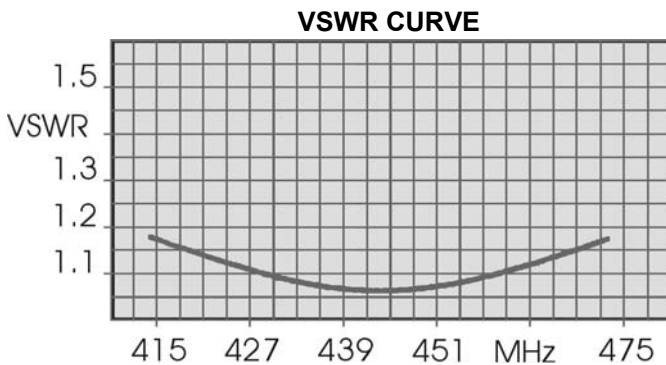
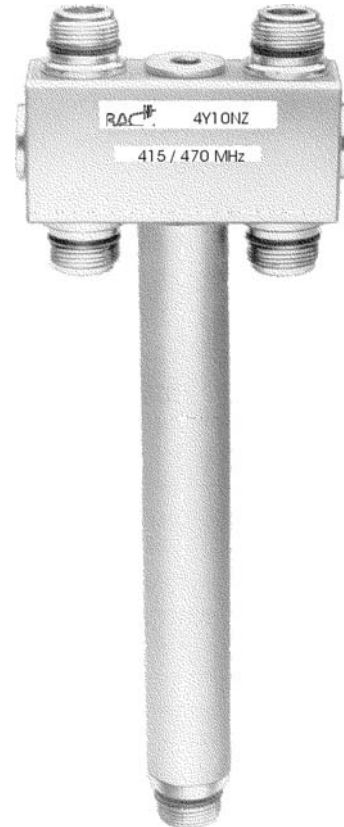

**MAIN CHARACTERISTICS**

Model	: <b>CMB U2</b> (2 couplers)
Type	: Coaxial
Frequency range	: 450 MHz
Input impedance	: 50 ohm
Output impedance	: 50 ohm
V.S.W.R.	: < 1:1.07
Return loss	: - 31.4 dB
Useful band width	: 100 MHz (- 50 + 50 MHz)
Maximum rated RF power	: 10 watt
Type f connection	: N Female
Dimensions	: 200 x 95 mm
Net weight	: abt. 830 g

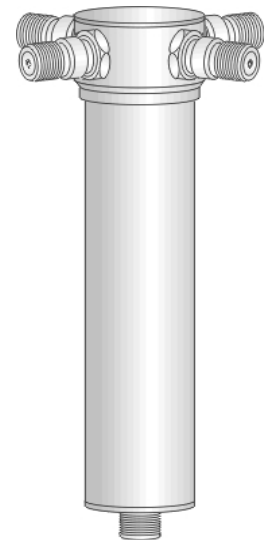

**CMB U**

**MAIN CHARACTERISTICS**

Model	: <b>CMB U3</b> (3 couplers)
Type	: Coaxial
Frequency range	: 450 MHz
Input impedance	: 50 ohm
Output impedance	: 50 ohm
V.S.W.R.	: < 1:1.07
Return loss	: - 31.4 dB
Useful band width	: 90 MHz (- 45 + 45 MHz)
Maximum rated RF power	: 10 watt
Type f connection	: N Female
Dimensions	: 200 x 95 mm
Net weight	: abt. 850 g

**MAIN CHARACTERISTICS**

Model	: <b>CMB U4</b> (4 couplers)
Type	: Coaxial
Frequency range	: 450 MHz
Input impedance	: 50 ohm
Output impedance	: 50 ohm
V.S.W.R.	: < 1:1.07
Return loss	: - 31.4 dB
Useful band width	: 80 MHz (- 40 + 40 MHz)
Maximum rated RF power	: 10 watt
Type f connection	: N Female
Dimensions	: 200 x 95 mm
Net weight	: abt. 880 g

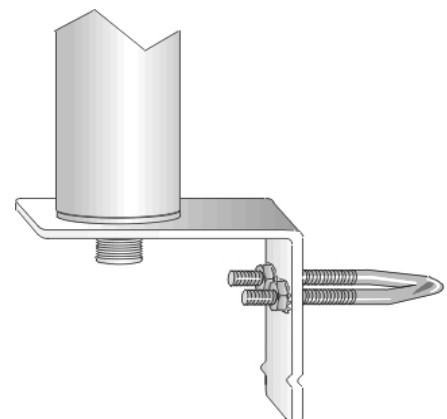

**MOUNTING**

**MAIN CHARACTERISTICS**

Model : **CMB V2** (2 couplers)  
 Type : Coaxial  
 Frequency range : 150 MHz  
 Input impedance : 50 ohm  
 Output impedance : 50 ohm  
 V.S.W.R. : < 1:1.07  
 Return loss : - 31.4 dB  
 Useful band width : 34 MHz (- 17 + 17 MHz)  
 Maximum rated RF power : 10 watt  
 Type f connection : N Female  
 Dimensions : 550 x 95 mm  
 Net weight : abt. 2510 g

**MAIN CHARACTERISTICS**

Model : **CMB V3** (3 couplers)  
 Type : Coaxial  
 Frequency range : 450 MHz  
 Input impedance : 50 ohm  
 Output impedance : 50 ohm  
 V.S.W.R. : < 1:1.07  
 Return loss : - 31.4 dB  
 Useful band width : 30 MHz (- 15 + 15 MHz)  
 Maximum rated RF power : 10 watt  
 Type f connection : N Female  
 Dimensions : 550 x 95 mm  
 Net weight : abt. 2520 g

**MAIN CHARACTERISTICS**

Model : **CMB V4** (4 couplers)  
 Type : Coaxial  
 Frequency range : 450 MHz  
 Input impedance : 50 ohm  
 Output impedance : 50 ohm  
 V.S.W.R. : < 1:1.07  
 Return loss : - 31.4 dB  
 Useful band width : 26 MHz (- 13 + 13 MHz)  
 Maximum rated RF power : 10 watt  
 Type f connection : N Female  
 Dimensions : 550 x 95 mm  
 Net weight : abt. 2550 g

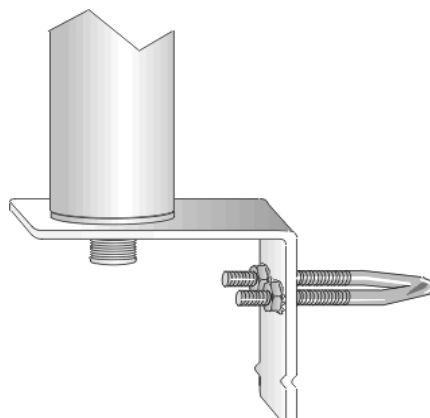
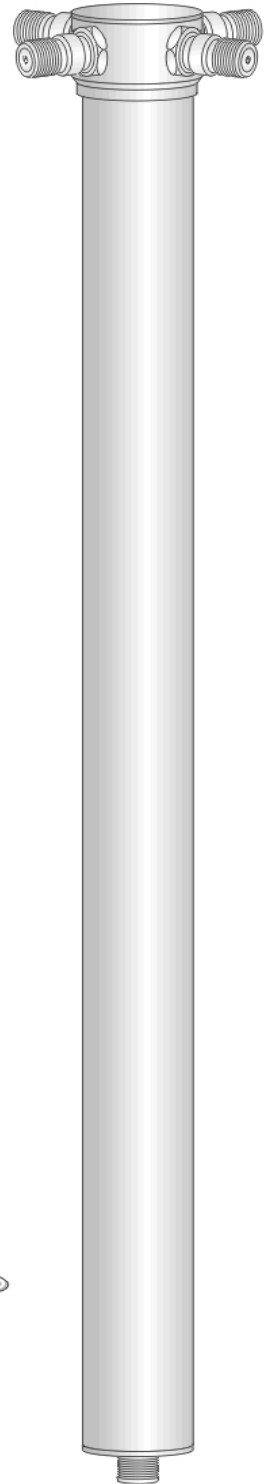

**MOUNTING**

**CMB V**

Model : **DS2** (2 couplers)  
 Type : Microstripline  
 Frequency : 2440 - 2485 MHz  
 Insertion loss : < 0.1 dB  
 Input impedance : 50 ohm  
 Outputs : 50 ohm  
 Type of connection : SMA female  
 Dimensions : 81 x 35 x 25 mm  
 Net weight : 36 g

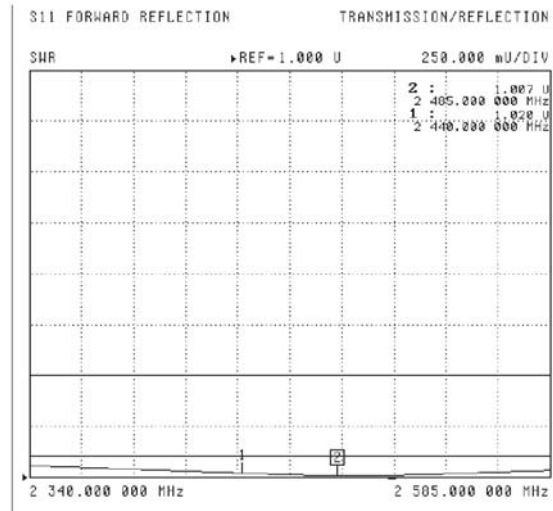

Model : **DS3** (3 couplers)  
 Type : Microstripline  
 Frequency : 2440 - 2485 MHz  
 Insertion loss : < 0.1 dB  
 Input impedance : 50 ohm  
 Outputs : 50 ohm  
 Type of connection : SMA female  
 Dimensions : 81 x 35 x 25 mm  
 Net weight : 38 g

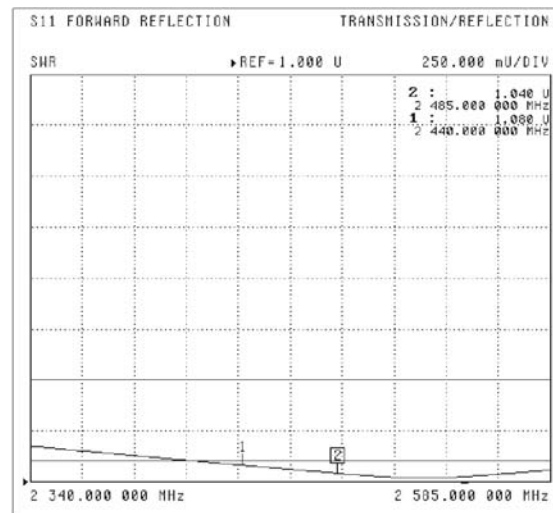

Model : **DS4** (4 couplers)  
 Type : Microstripline  
 Frequency : 2440 - 2485 MHz  
 Insertion loss : < 0.1 dB  
 Input impedance : 50 ohm  
 Outputs : 4 x 50 ohm  
 Type of connection : SMA female  
 Dimensions : 81 x 35 x 25 mm  
 Net weight : 42 g

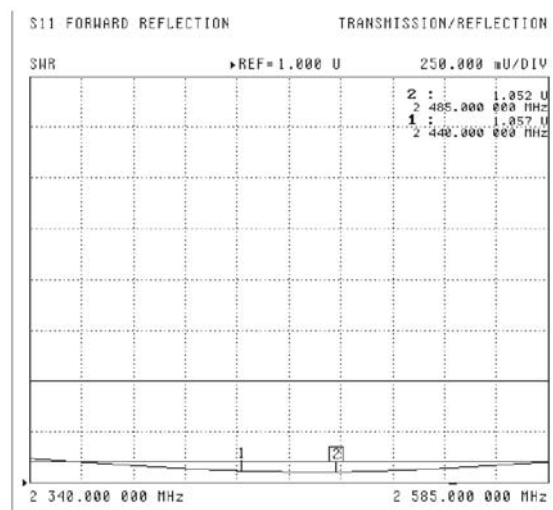

**MAIN CHARACTERISTICS**

Model	: <b>CR 3</b>
Frequency range	: Cellular 900 MHz : Car Radio OM/FM and 26 - 28 MHz
Input impedance	: 50 ohm
Insertion loss	: < 0.4 dB
Separation	: > 30 dB
Maximum rated RF power	: 10 watt
Type f connection	: FME male and ISO DIN male
Usage	: With antenna mod. UNIKA SUPERTRIS
Dimensions	: 25 x 58 x 98 mm
Net weight	: abt. 80 g

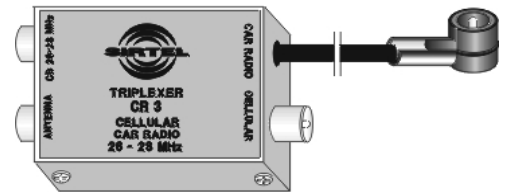

**MAIN CHARACTERISTICS**

Model	: <b>CR 3U</b>
Frequency range	: Cellular 900 MHz : Car Radio OM/FM and 210 - 470 MHz
Input impedance	: 50 ohm
Insertion loss	: < 0.4 dB
Separation	: > 30 dB
Maximum rated RF power	: 10 watt
Type f connection	: FME male and ISO DIN male
Usage	: With antenna mod. UBC 9
Dimensions	: 25 x 58 x 98 mm
Net weight	: abt. 80 g

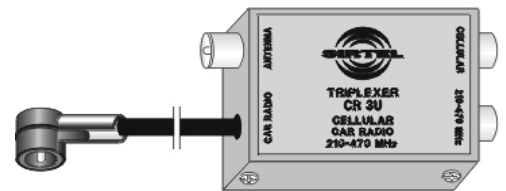

**MAIN CHARACTERISTICS**

Model	: <b>CR 3V</b>
Frequency range	: Cellular 900 MHz : Car Radio OM/FM and 26 - 28 MHz
Input impedance	: 50 ohm
Insertion loss	: < 0.4 dB
Separation	: > 30 dB
Maximum rated RF power	: 10 watt
Type f connection	: FME male and ISO DIN male
Usage	: With antenna mod. VBC 9
Dimensions	: 25 x 58 x 98 mm
Net weight	: abt. 80 g

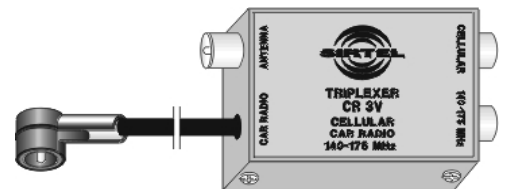

**MAIN CHARACTERISTICS**

Model	: <b>CR A98</b> (With Car Radio Amplifier)
Frequency range	: Cellular 900 MHz and 1800 MHz : Car Radio OM/FM
Input impedance	: 50 ohm
Insertion loss	: < 0.4 dB
Separation	: > 30 dB
Maximum rated RF power	: 10 watt
Type f connection	: Pigtails with FME male and ISO DIN male
Usage	: With antenna mod. SH 918
Dimensions	: 25 x 58 x 98 mm
Net weight	: abt. 80 g

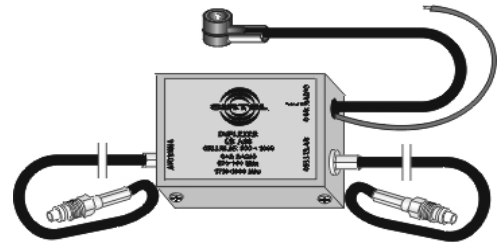

**MAIN CHARACTERISTICS**

Model	: <b>DIV 900</b> (2 antennas coupler)
Frequency range	: 870 - 960 MHz
Input impedance	: 50 ohm
Insertion loss	: < 0.4 dB
Separation	: > 30 dB
Maximum rated RF power	: 10 watt
Type f connection	: FME male and Pigtails with FME female
Usage	: With antenna mod. SKELETON 900
Dimensions	: 25 x 58 x 98 mm
Net weight	: abt. 80 g

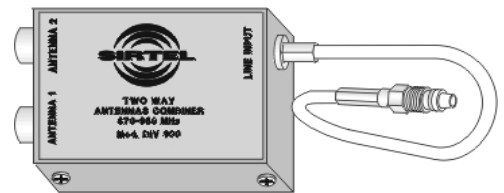

**MAIN CHARACTERISTICS**

Model	: <b>D 49</b>
Frequency range	: UHF 380 - 470 MHz : UHF 870 - 960 MHz
Input impedance	: 50 ohm
Insertion loss	: < 0.4 dB
Separation	: > 30 dB
Maximum rated RF power	: 10 watt
Type f connection	: TNC male
Usage	: With antenna mod. LP
Dimensions	: 25 x 58 x 98 mm
Net weight	: abt. 80 g



---

## MAIN CHARACTERISTICS

Frequency range	: 25 - 1000 MHz
Maximum rated RF power	: 250 watt
Type of connection	: 4.5 m of M17/028-RGO58 coaxial cable
Magnetic force	: 350 N
Mounting	: On steel surface
Base material	: Stabilizad polycarbonate (ASTM D 256)
Dimensions	: 105 x 58 mm
Net weight	: abt. 900 g
Working temperature	: From -35° to +80°

The particular design of the magnetic circuit offers considerable overturning resistance and high attaching effect, with enough depth of field to avoid disjunction due to the bounce effects. The electric circuit with silver-plated contact points, protected by silicon rubber, can assume frequency range up to 1 GHz. The coaxial cable is connected to the base by a tearing resistant system. The stabilized polycarbonate base gives high mechanical strenght against impacts. The replaceable elastomeric protective cap protect the body of vehicle from contact damages and allows the use of the base mount starting from -35°.



## MAIN CHARACTERISTICS

Frequency range	: 880 - 960 MHz : 1710 - 1880 MHz : 2440 2485 MHz
Input impedance	: 50 ohm
V.S.W.R.	: < 1:1.7
Insertion loss	: < 0.4 dB 900 MHz : < 0.7 dB 1800 MHz : < 1.2 dB 2400 MHz
Separation	: > 30 dB 900 - 2400 MHz : > 22 dB 1800 - 2400 MHz : > 26 dB 2400 - 1800 MHz
Maximum rated RF power	: 5 watt
Type f connection	: TNC female and FME female (900 - 1800 MHz) : SMA male (2400 MHz)
Dimensions	: 113 x 63 x 55 mm
Usage	: With antenna mod. LP 903-18-24-GN





Weatherproof connector with threaded coupling.

Conforming to MIL-C-39012 this connector is specially designed to resist in extreme environmental conditions. Widely used connector for applications that required waterproof also with strong vibrations.

The hexagonal fixing ferrule allows a sure block, and the possibility of get off

---

### MAIN CHARACTERISTICS

Input impedance	: 50 ohm
V.S.W.R.	: < 1.2:1
V.S.W.R. (1 gate open)	: N.A.
Maximum rated RF power	: 1000 watt
Insertion loss	: < 0.3 Db
Type of connection	: 7 - 16 female (DIN 47223)
Hermetic seal	: Pass helium leak test of 1x10 <sup>-10</sup> cc/sec
Inner conductor	: Brass silver plated
Housing material	: Aluminium alloy DIN 3.3206
Net weight	: 250 g
Dimensions	: 29 x 75 x 81 mm
Working temperature	: From -35° to +80°



Conforming to MIL-C-39012  
This connector is specially designed to resist  
in extreme environmental conditions.

---

## MAIN CHARACTERISTICS

Frequency range	: DC to 1500 MHz
Input impedance	: 50 ohm
V.S.W.R.	: < 1.01:1
Peak voltage	: 2.5 kV
Operating voltage	: 1 kV
Insulation resistance	: 5 G/ohm
Contact resistance	: > 1 G/ohm
Least nr. of mating cycles	: 500
Working temperature	: From -35° to +80°
Cable retention	: 500 N
Coupling torque	: 2 Nm
Corrosion resistance	: According to MIL-STD 202 (101B)
Proof resistance	: 295 kPa
Climatic category	: IEC 55/155/21



**EXPLODED VIEW**